



Thank You!

You have successfully downloaded your document from Workbenchmagazine.com. Below are some tips for Trouble-Free Printing

- 1)** Clear printer memory. If you are unable to print this document, turn off your printer for at least 15 seconds and try again.
- 2)** Print two or three pages at a time. If clearing the printer memory didn't help, try printing only two or three pages at one time, rather than sending the entire file
- 3)** If a document is required to be at an accurate scale set the page scaling option to "none" in your printer settings.
- 4)** Get advanced printer help. Visit Adobe Support for instructions in troubleshooting common printer problems.

<http://www.adobe.com/support/techdocs/316508.html>

MATERIALS LIST



CODE	DESCRIPTION	QTY.	Dim1	Frac.	Dim2	Frac.	Dim3	Frac.	Material
SIDE RAIL ASSEMBLY									
A	Side Rail	(2)	3/4"	x	11 1/4"	-	91 1/2"		Birch Ply
B	Leg Sides	(12)	3/4"	x	5"	-	11 1/4"		Poplar
C	Side Rail Support Cleat	(2)	3/4"	x	1 1/2"	-	81 1/2"		Poplar
D	Side Rail Cap	(2)	3/4"	x	7 1/4"	-	94 1/2"		Poplar
E	Side Rail Bolster	(2)	3/4"	x	1 1/2"	-	94 1/2"		Poplar
F	Side Rail End Bolster	(2)	3/4"	x	1 1/2"	-	5 3/4"		Poplar
G	Platform Corner Cleat	(2)	3/4"	x	1 1/2"	-	5"		Poplar
H	Slat Support Cleat	(2)	3/4"	x	1 1/2"	-	79"		Poplar
FOOTER ASSEMBLY									
I	Footer	(1)	3/4"	x	11 1/4"	-	61"		Birch Ply
J	End Rail Support Cleat	(1)	3/4"	x	1 1/2"	-	58"		Poplar
K	End Rail Cap	(1)	3/4"	x	7 1/4"	-	61"		Poplar
L	End Rail Bolster	(1)	3/4"	x	1 1/2"	-	61"		Poplar
HEADBOARD ASSEMBLY									
M	Header	(1)	3/4"	x	11 1/4"	-	61"		Birch Ply
N	Stanchion	(2)	3/4"	x	5 1/2"	-	28 1/4"		Poplar
O	Cap Cleat	(2)	3/4"	x	3/4"	-	5 1/2"		Poplar
P	Rung Cleat	(2)	3/4"	x	3/4"	-	15 1/2"		Poplar
Q	Rung	(8)	3/4"	x	1 1/2"	-	61"		Poplar
R	Headboard Cap Rail	(1)	3/4"	x	9 1/2"	-	90"		Poplar
S	Cap Rail Bolster	(1)	3/4"	x	1 1/2"	-	90"		Poplar
T	Cap Rail End Bolster	(2)	3/4"	x	1 1/2"	-	8"		Poplar
U	Slats	(14)	3/4"	x	3 1/4"	-	60 15/16"		Fir

- 1 set of Surface mount bed rail brackets - Rockler #38892
- (90) #8 x 1 1/4" Flathead Wood Screws
- (44) #8 x 2" Flathead Wood Screws
- (64) 18-ga. x 1 1/2" Brad Nails

workbench® Platform Bed

Issue 309 Volume 64 Number 5

October 2008

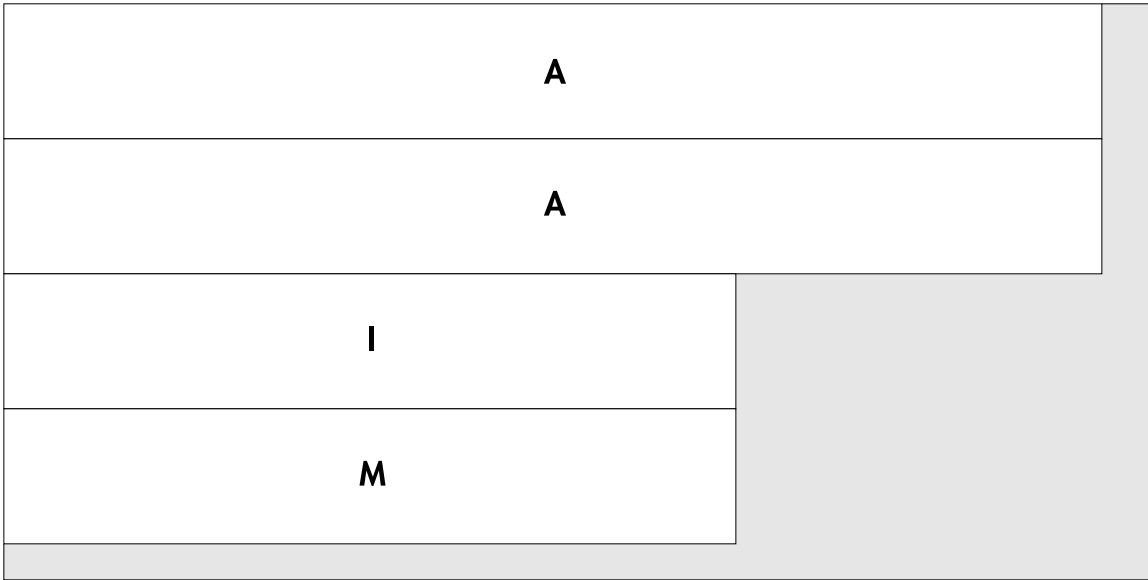

$\frac{3}{4}$ " x 48" x 96" birch plywood

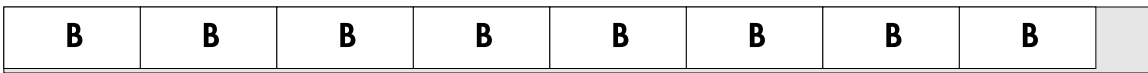

$\frac{3}{4}$ " x 5 $\frac{1}{2}$ " x 96" Poplar

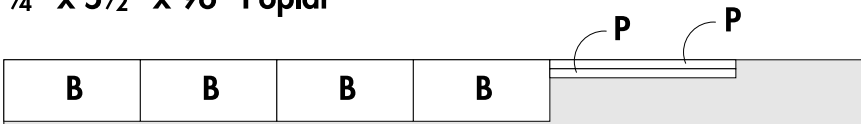

$\frac{3}{4}$ " x 5 $\frac{1}{2}$ " x 72" Poplar

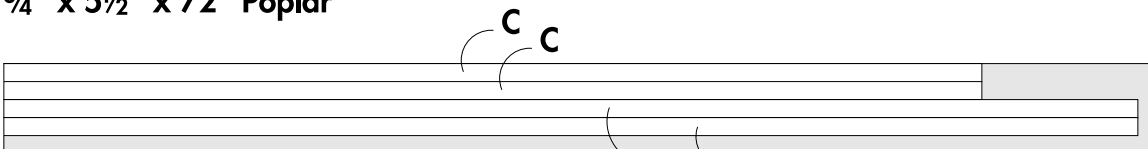

$\frac{3}{4}$ " x 7 $\frac{1}{4}$ " x 96" Poplar



(2) $\frac{3}{4}$ " x 7 $\frac{1}{4}$ " x 96" Poplar

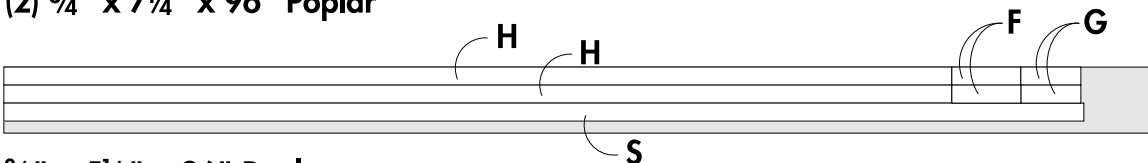

$\frac{3}{4}$ " x 5 $\frac{1}{2}$ " x 96" Poplar

CUTTING DIAGRAM

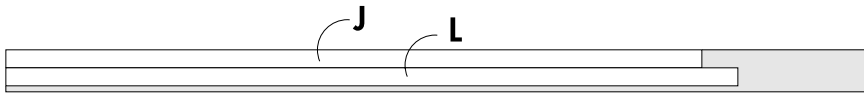

$\frac{3}{4}$ " x $3\frac{1}{2}$ " x 72" Poplar



$\frac{3}{4}$ " x $7\frac{1}{4}$ " x 72" Poplar



$\frac{3}{4}$ " x $5\frac{1}{2}$ " x 72" Poplar

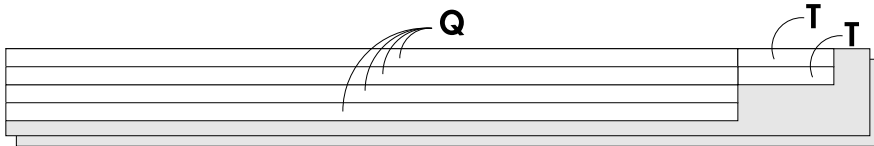

(2) $\frac{3}{4}$ " x $7\frac{1}{4}$ " x 72" Poplar



$\frac{3}{4}$ " x $9\frac{1}{2}$ " x 96" Poplar



(14) $\frac{3}{4}$ " x $3\frac{1}{2}$ " x 72" Fir

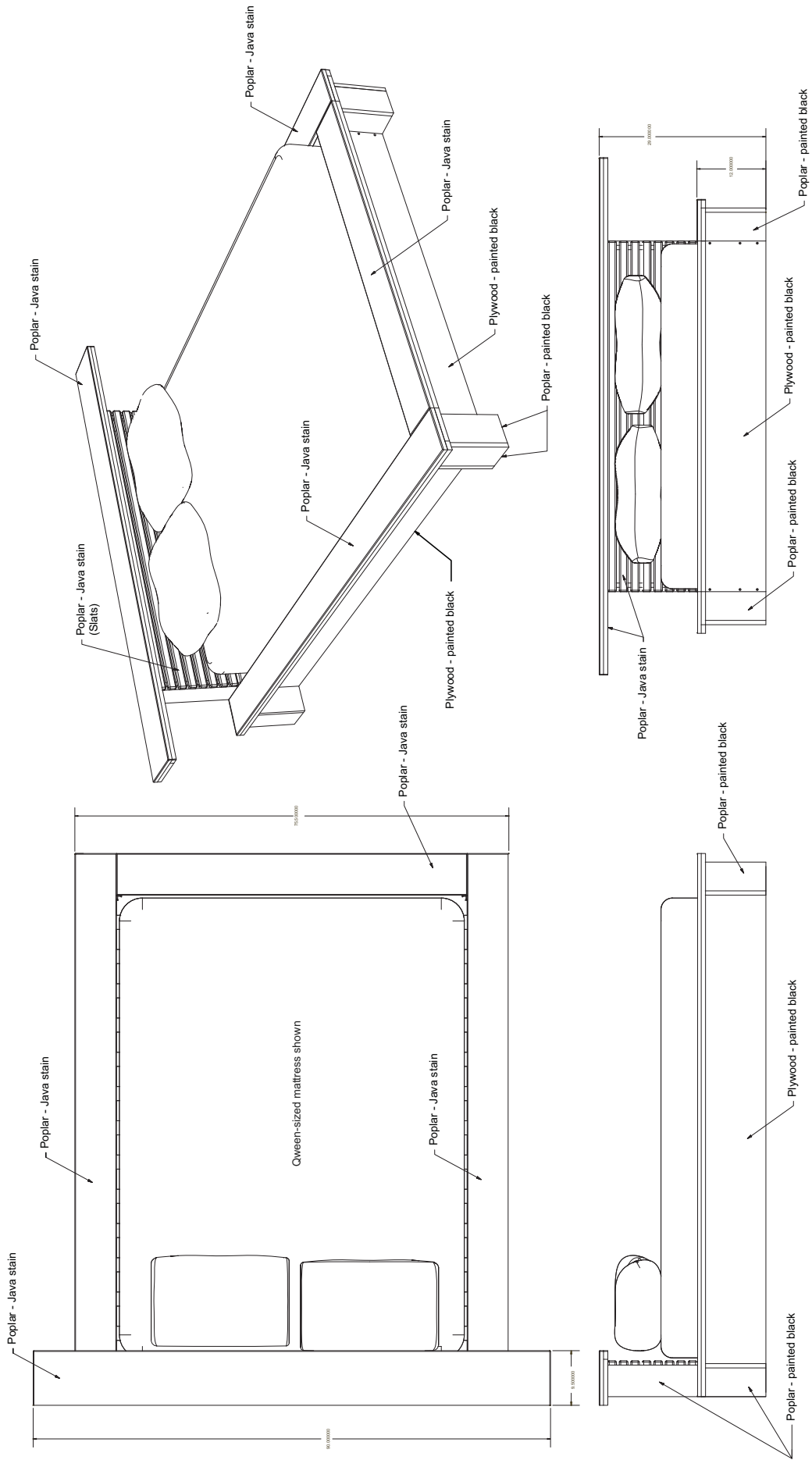

Construction Note
 Assemble using glue & brad nailer,
 except where shown otherwise.

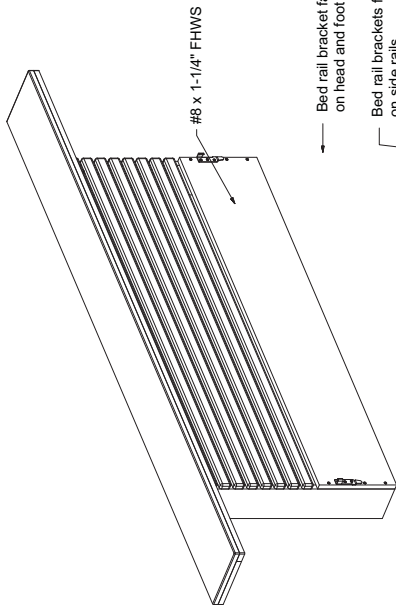

DRAWING REVISED 7.7.08
 (Destroy old copies & replace with this version)

#8 x 1-1/4" FHWS

Bed rail bracket faces down on head and foot rails

Bed rail brackets face up on side rails

(14) 3/4 x 3-1/2 x 60-15/16" fir bed slats

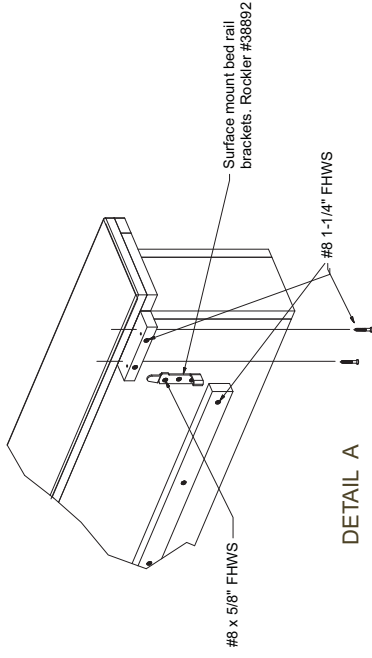

DETAIL A

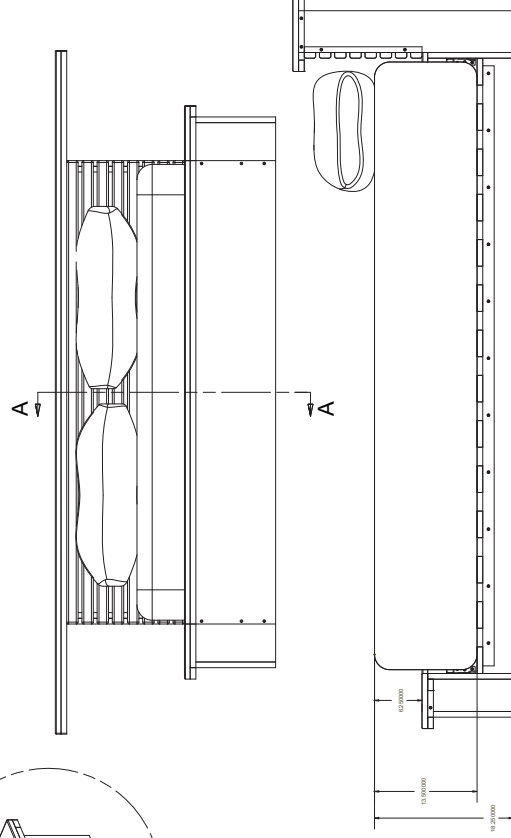
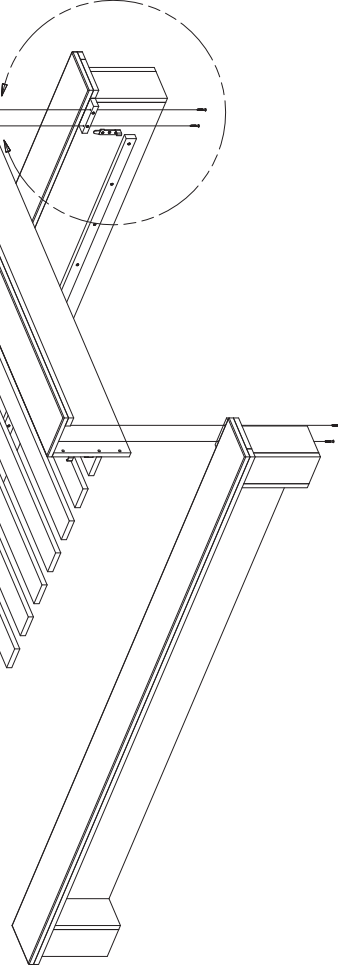

SECTION A-A

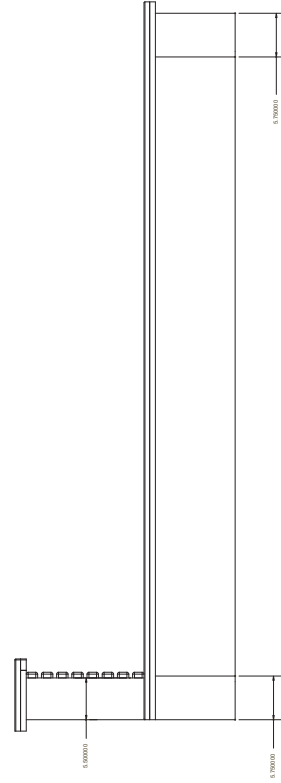

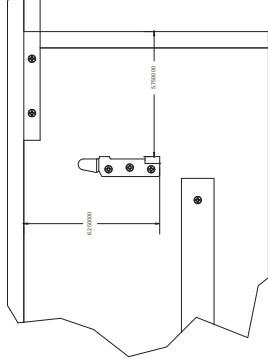
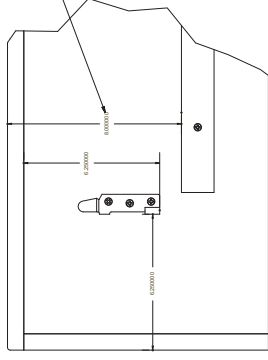
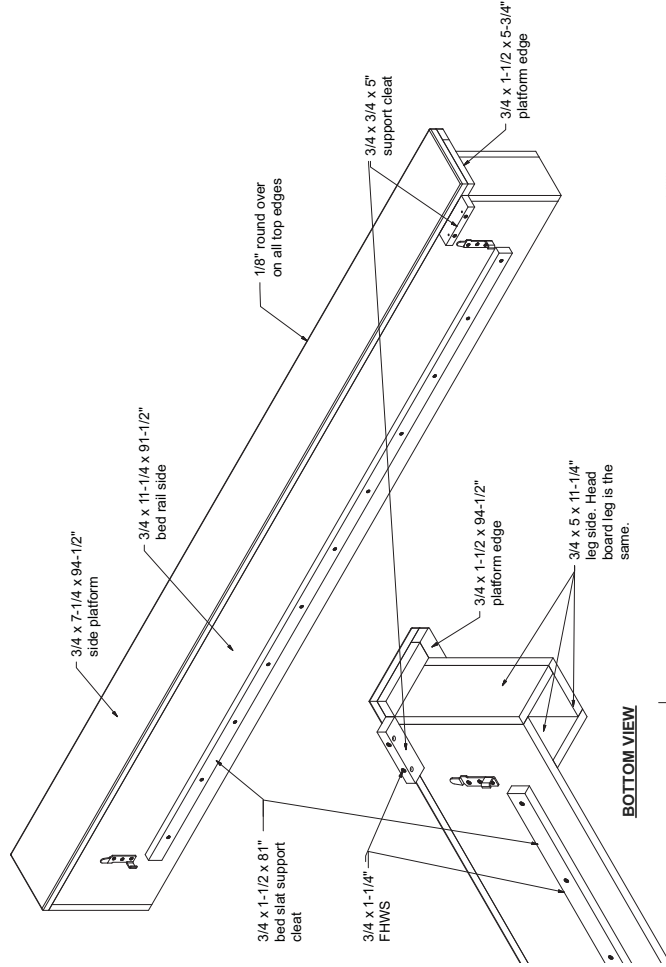

DRAWING REVISED 7.7.08
(Destroy old copies & replace with this version)

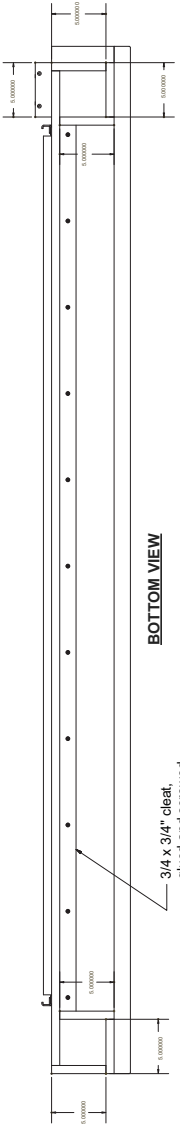
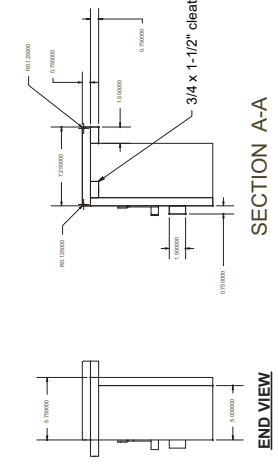
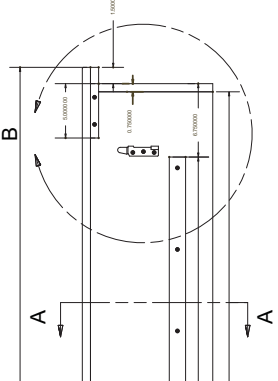
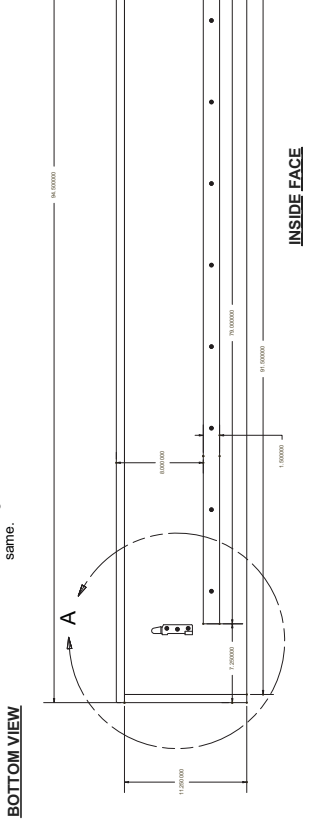

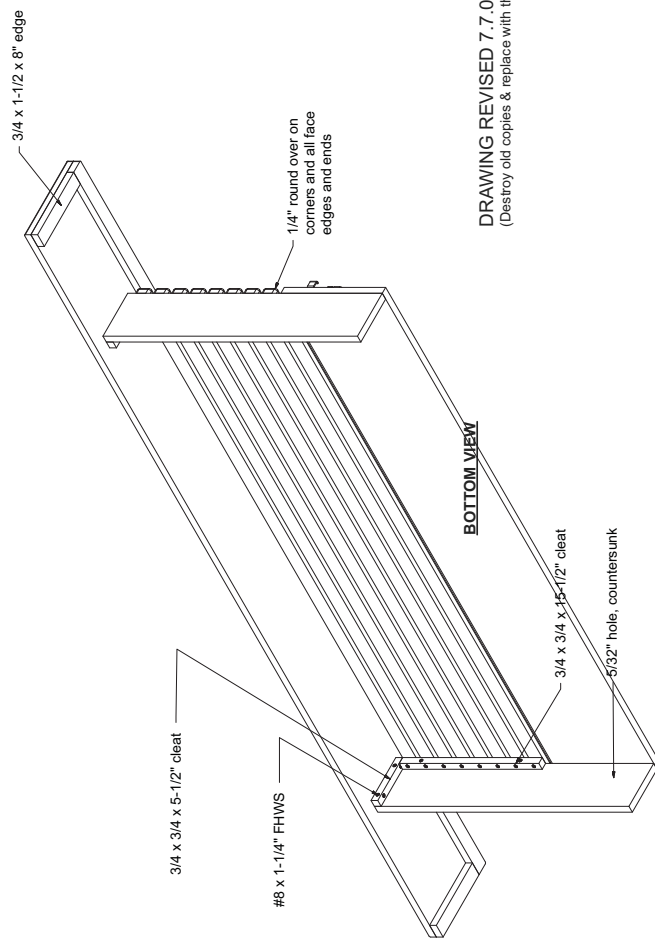

DRAWING REVISED 7.7.08
(Destroy old copies & replace with this version)

