



Thank You!

You have successfully downloaded your document from Workbenchmagazine.com. Below are some tips for Trouble-Free Printing

- 1)** Clear printer memory. If you are unable to print this document, turn off your printer for at least 15 seconds and try again.

- 2)** Print two or three pages at a time. If clearing the printer memory didn't help, try printing only two or three pages at one time, rather than sending the entire file

- 3)** If a document is required to be at an accurate scale set the page scaling option to "none" in your printer settings.

- 4)** Get advanced printer help. Visit Adobe Support for instructions in troubleshooting common printer problems.

<http://www.adobe.com/support/techdocs/316508.html>

MATERIALS LIST



MATERIAL LIST

Part	Qty	Size	Material	
STORAGE BENCH				
A	TOP/BOTTOM	2	3/4" x 15 1/2" x 31"	Oak Plywood
B	END PANELS	2	3/4" x 15" x 14 3/4"	Oak Plywood
C	DIVIDER	1	3/4" x 14" x 14 1/2"	Oak Plywood
D	EDGING	1	1/4" x 3/4" x cut to fit	Oak
E	BACK PANEL	1	1/4" x 14 1 5/16" x 30 3/8"	Oak Plywood
BENCH TOP/BASE				
F	TOP/BASE	2	1 1/2" x 14 1 5/16" x 30 3/8"	MDF
G	BANDING-FRONT	2	3/4" x 1 3/8" x 31 7/8"	Poplar
H	BANDING-ENDS	4	3/4" x 1 3/8" x 15 1/16"	Poplar

Part	Qty	Size	Material	
BENCH DOORS				
I	DOOR RAILS	4	3/4" x 2 1/2" x 10 1 5/16"	Poplar
J	DOOR STILES	4	3/4" x 2 1/2" x 15"	Poplar
K	GLASS STOP	1	1/4" x 1/4" x cut to fit	Poplar

HARDWARE (see Buyer's Guide for Pulls, Legs, & Glass):

- (14) #8 x 2" Fh Woodscrews
 - (16) 1 1/4" Washer-head Pocket Screws
 - (16) #8 x 1 1/4" Ph Woodscrews
 - (2 pr.) 107° Full-Overlay Hinges (#00B10.01)*
- *Items available from Lee Valley (LeeValley.com; 800-871-8158)

CUTTING DIAGRAM

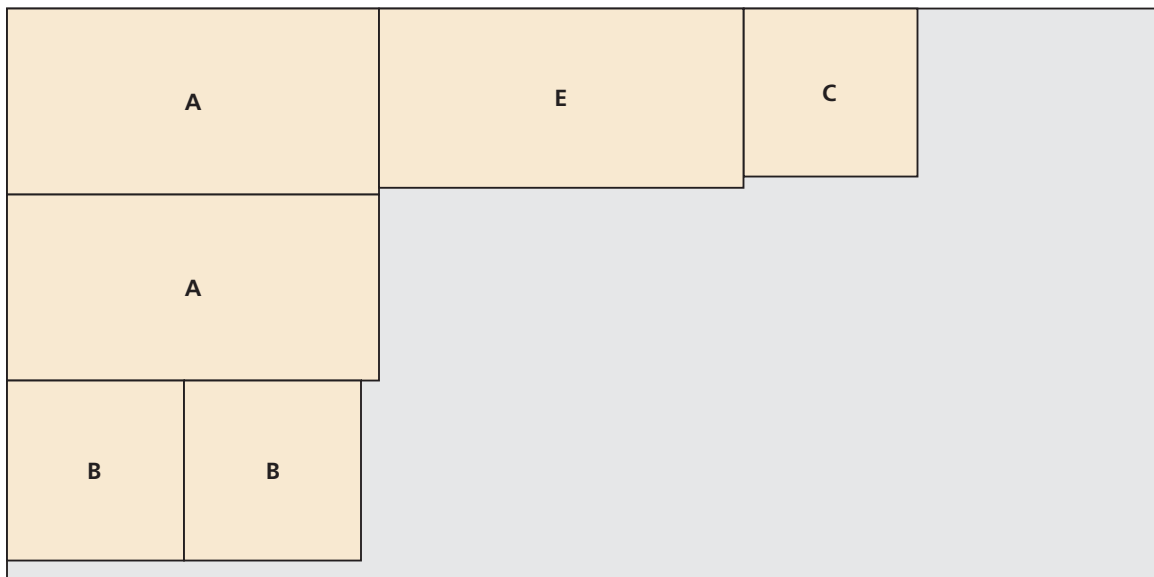

3/4" X 48" X 96" Rift Sawn Red Oak Plywood

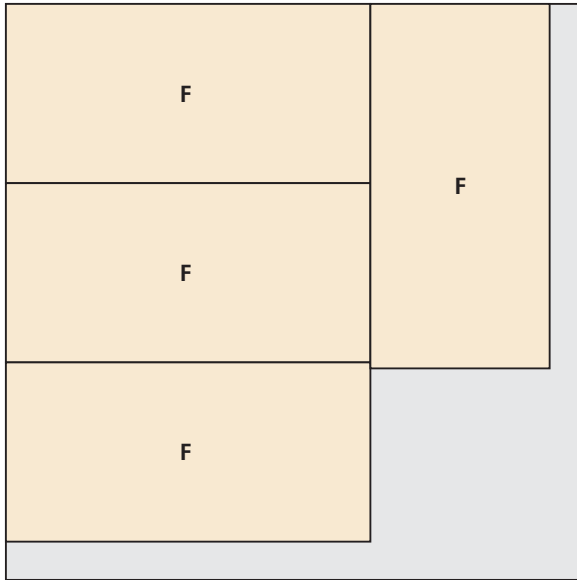
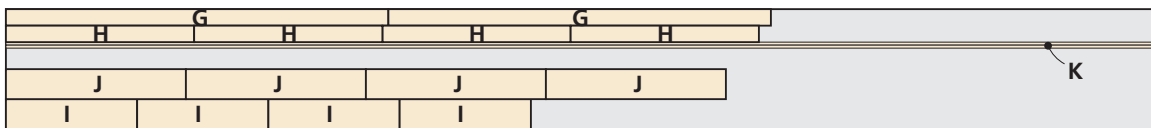
CUTTING DIAGRAM**3/4" X 48" X 48" MDF****1/4" X 2" X 96" Rift Sawn Red Oak****1/4" X 10" X 96" Poplar**

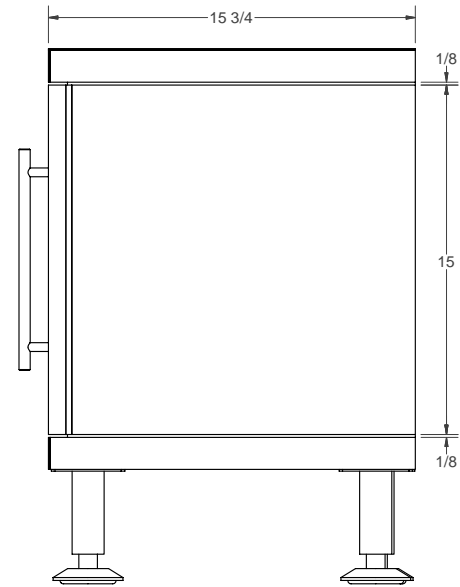
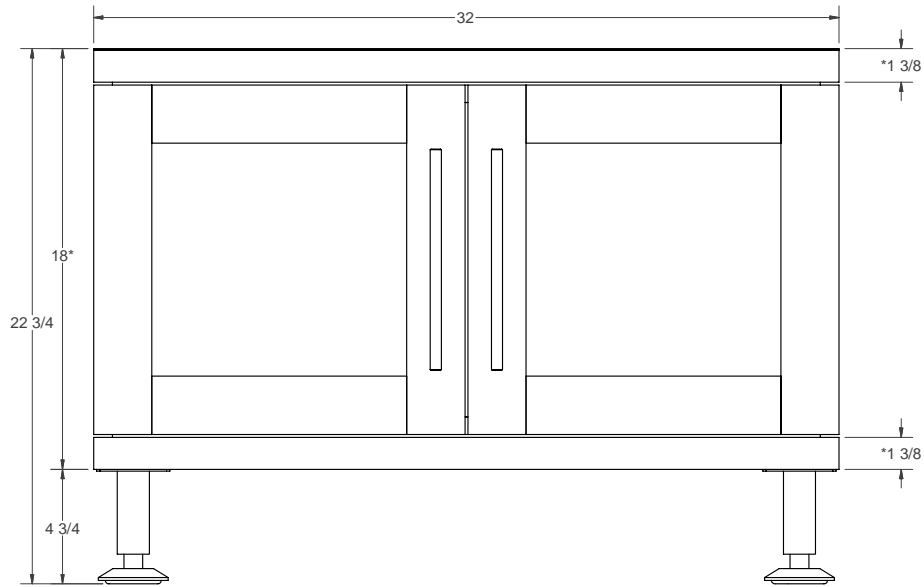
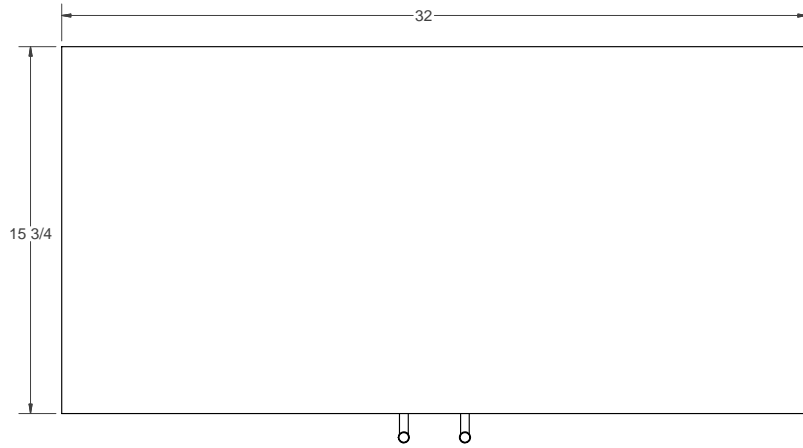

WORKBENCH #298	BATHROOM REMODEL	STORAGE BENCH	DATE 5/30/06	DRAWN 1/9
----------------	------------------	---------------	-----------------	--------------

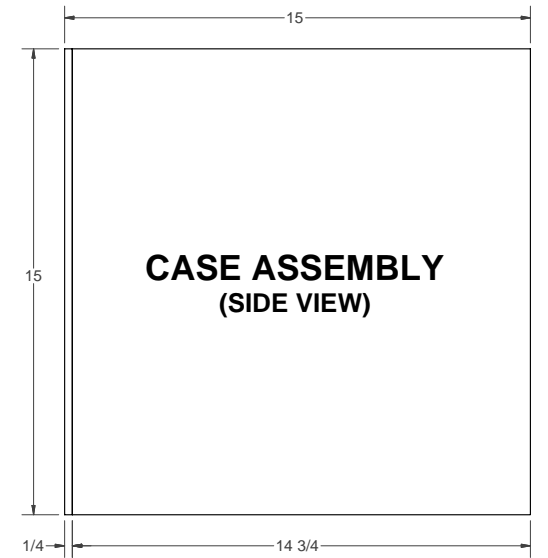
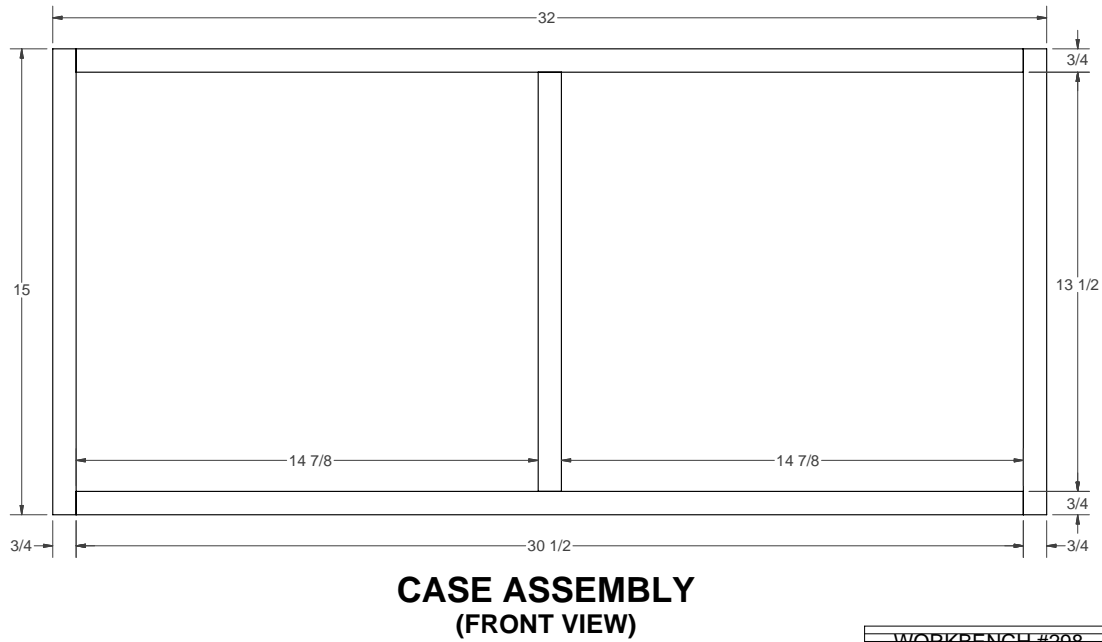
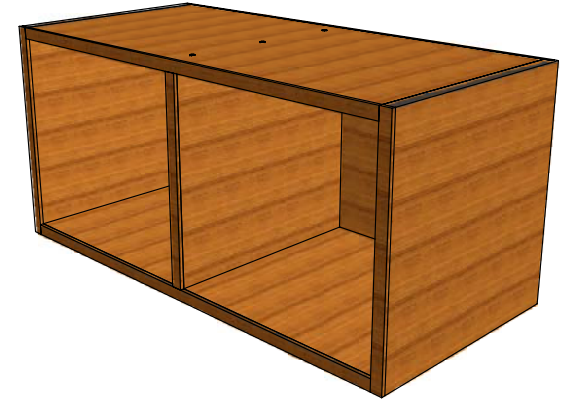
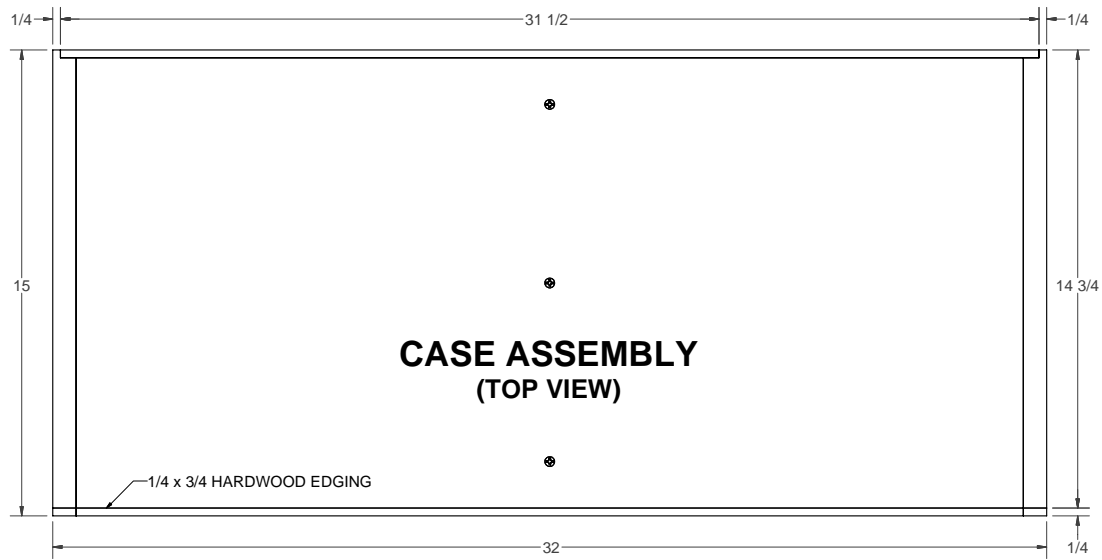

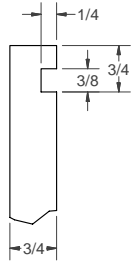

JOINERY DETAIL (TOP)

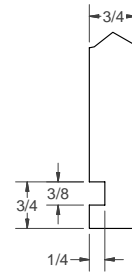

JOINERY DETAIL (BOTTOM)

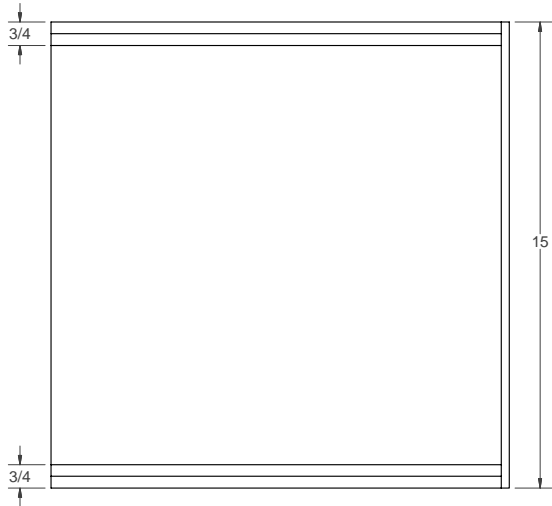
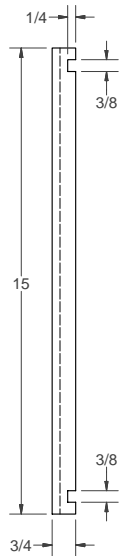
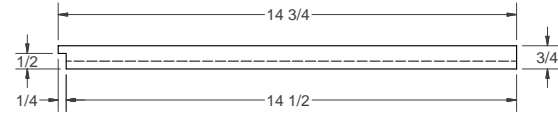
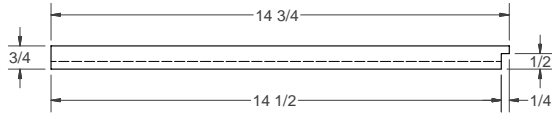

LEFT END PANEL

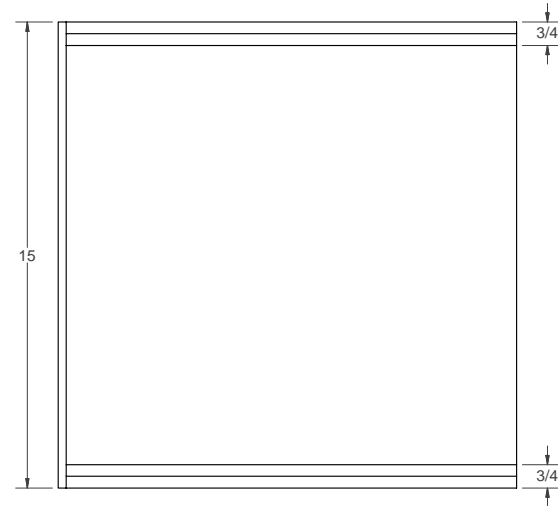

RIGHT END PANEL

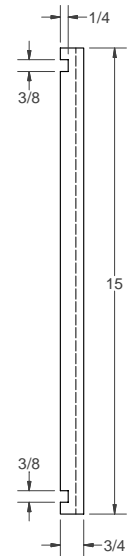

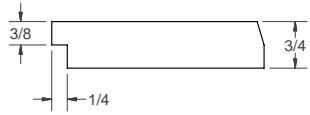

END JOINERY DETAIL

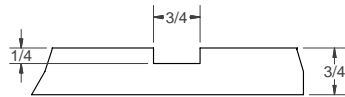

DADO DETAIL

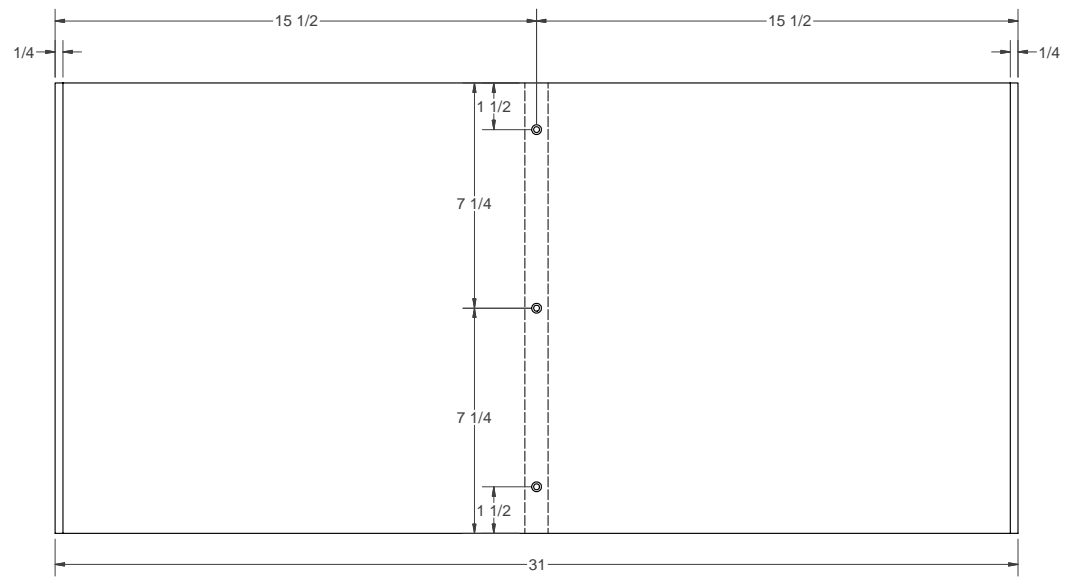
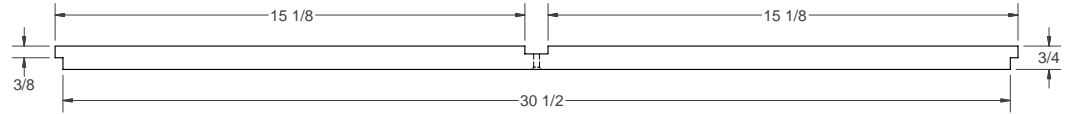

CASE BOTTOM PANEL

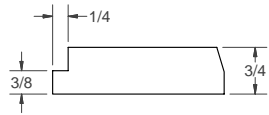

END JOINERY DETAIL

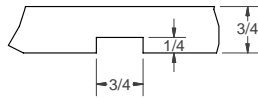

DADO DETAIL

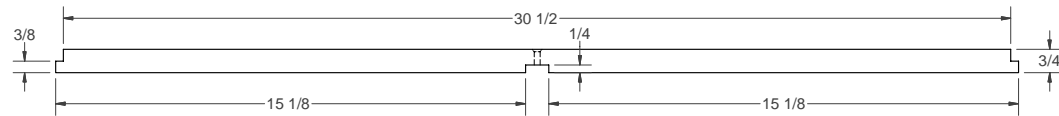
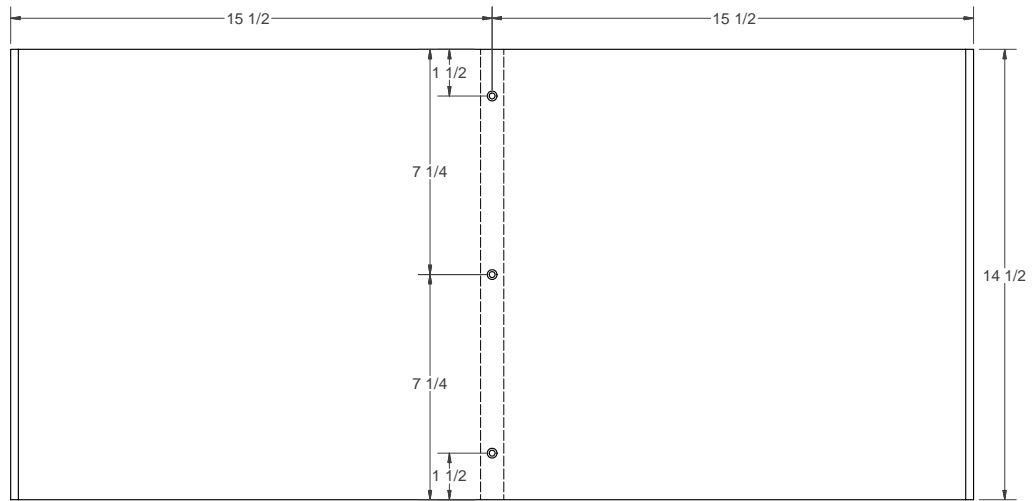

CASE TOP PANEL

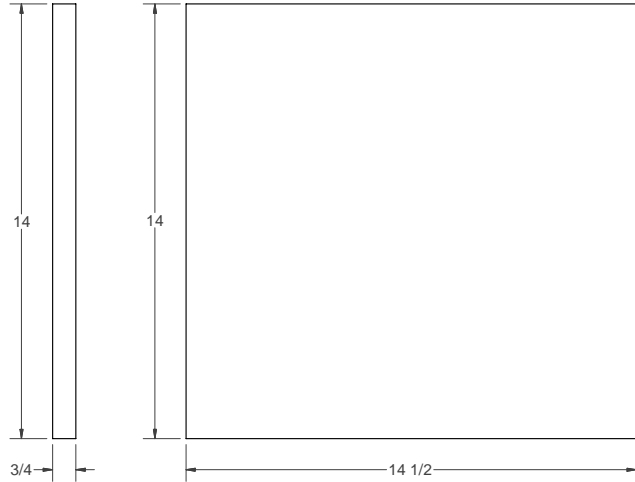
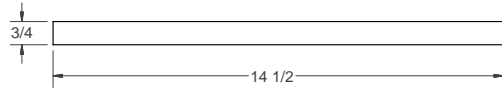

CASE DIVIDER PANEL

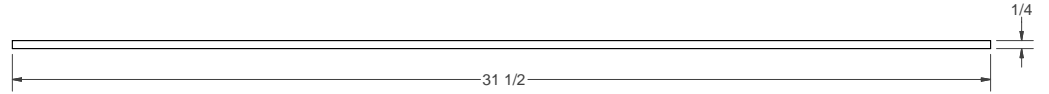

CASE BACK



**TOP PANEL
(FRONT VIEW)**

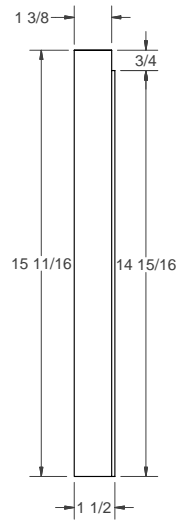

**TOP PANEL
(SIDE VIEW)**

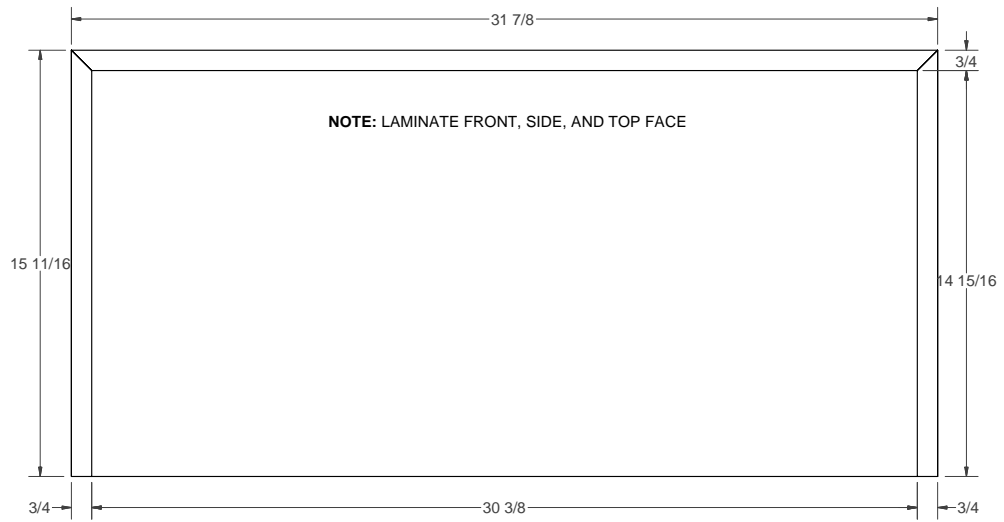

**TOP PANEL
(BOTTOM VIEW)**

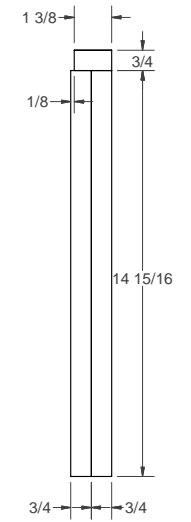

**TOP PANEL
(SIDE SECTION VIEW)**

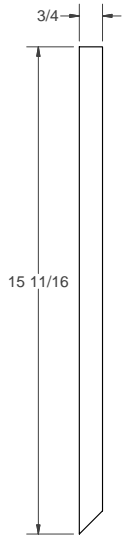

**SIDE PANEL
EDGING**

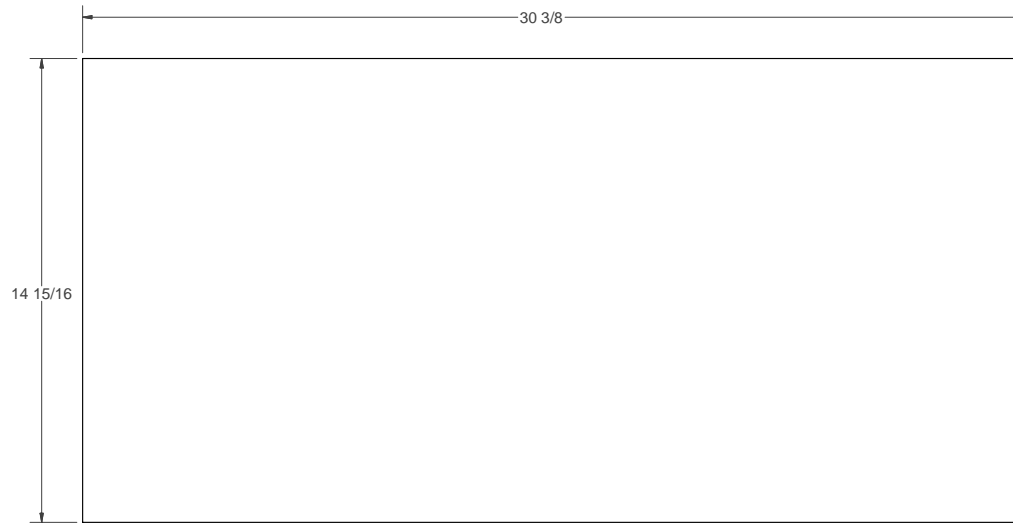

**TOP PANEL
(NEED 2)**

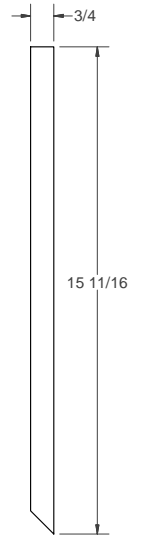

**SIDE PANEL
EDGING**

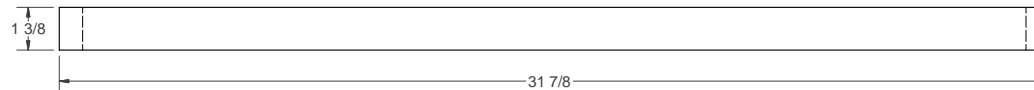
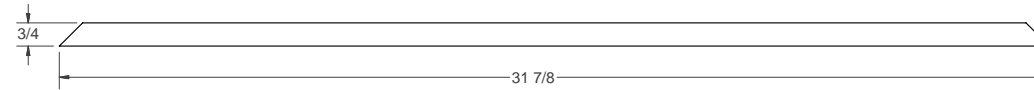
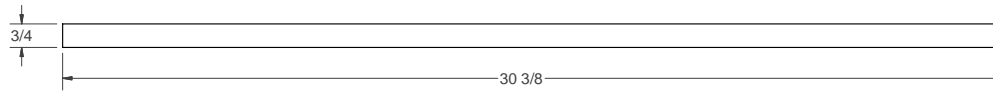

FRONT PANEL EDGING

NOTE: AFTER ASSEMBLY, ROUT A 3/8 x 1/2 DEEP RABBET AROUND THE INSIDE EDGE OF THE FRAME (ON THE BACK SIDE) TO RECIEVE GLASS

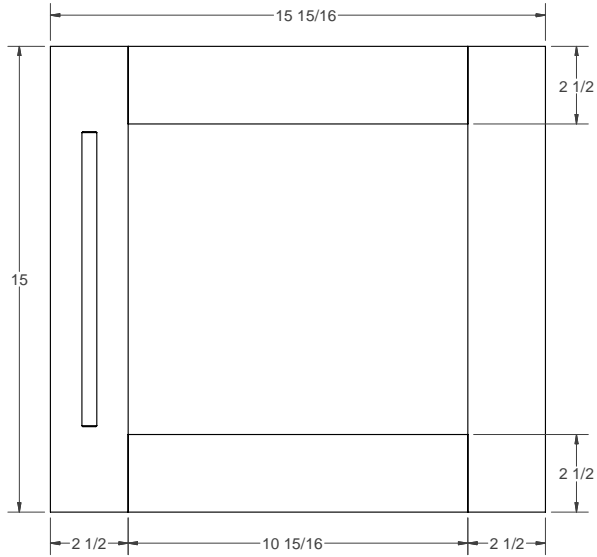
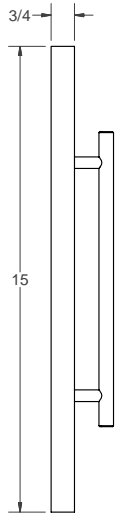
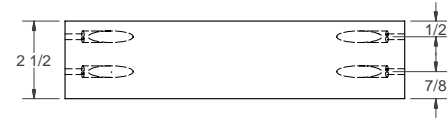
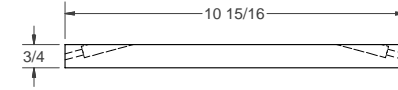
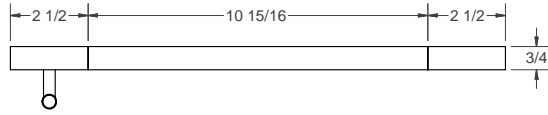

DOOR ASSEMBLY

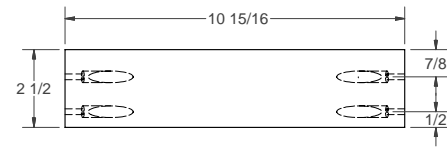
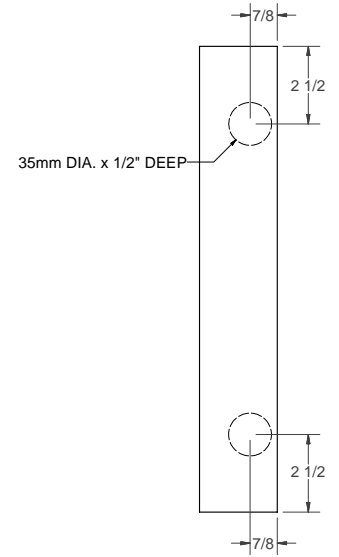
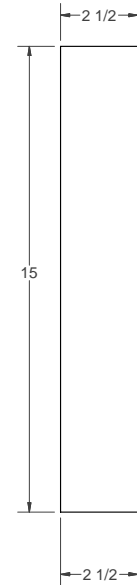

DOOR COMPONENTS