



# Thank You!

---

**You have successfully downloaded your document from Workbenchmagazine.com. Below are some tips for Trouble-Free Printing**

- 1)** Clear printer memory. If you are unable to print this document, turn off your printer for at least 15 seconds and try again.
  
- 2)** Print two or three pages at a time. If clearing the printer memory didn't help, try printing only two or three pages at one time, rather than sending the entire file
  
- 3)** If a document is required to be at an accurate scale set the page scaling option to "none" in your printer settings.
  
- 4)** Get advanced printer help. Visit Adobe Support for instructions in troubleshooting common printer problems.

<http://www.adobe.com/support/techdocs/316508.html>

## MATERIAL AND HARDWARE LIST

A (2) Rear Leg (2x6)	$1\frac{1}{2}'' \times 5\frac{1}{2}'' \times 30\frac{5}{8}''$
B (2) Front Leg (2x4)	$1\frac{1}{2}'' \times 3\frac{1}{2}'' \times 22\frac{3}{4}''$
C (4) Seat Support (2x6)	$1\frac{1}{2}'' \times 5\frac{1}{2}'' \times 19\frac{3}{4}''$
D (2) Back Support (2x6)	$1\frac{1}{2}'' \times 5\frac{1}{2}'' \times 20\frac{1}{8}''$
E (1) Front Rail (2x4)	$1\frac{1}{2}'' \times 3\frac{1}{2}'' \times 48''$
F (1) Rear Rail (2x4)	$1\frac{1}{2}'' \times 3\frac{1}{2}'' \times 46\frac{1}{2}''$
G (2) Arm Rest (2x4)	$1\frac{1}{2}'' \times 3\frac{1}{2}'' \times 23\frac{1}{2}''$
H (1) Bottom Back Slat (1x6 decking)	$1\frac{1}{16}'' \times 3\frac{1}{2}'' \times 49\frac{1}{2}''$
I (10) Common Slat (1x6 decking)	$1\frac{1}{16}'' \times 2\frac{1}{2}'' \times 49\frac{1}{2}''$
J (1) Upper Slat (1x6 decking)	$1\frac{1}{16}'' \times 5\frac{1}{8}'' \times 49\frac{1}{2}''$
K (1) Front Slat (1x6 decking)	$1\frac{1}{16}'' \times 2\frac{1}{2}'' \times 46\frac{1}{2}''$
L (2) Arm Bracket (1x6 decking)	$1\frac{1}{16}'' \times 1'' \times 6''$
M (3) Decorative Diamonds (1x6 decking)	$\frac{1}{4}'' \times 1'' \times 1''$

### HARDWARE

- (16) #10 x 3" Stainless Steel Screws
- (10) #10 x 2 $\frac{1}{2}$ " Stainless Steel Screws
- (4) #10 x 2" Stainless Steel Screws
- (8) #10 x 1 $\frac{1}{4}$ " Stainless Steel Screws
- (102) #8 x 1 $\frac{1}{2}$ " Stainless Steel Screws
- (140)  $\frac{3}{8}$ " Wood plugs,  $\frac{5}{16}$ " long

## BENCH CONSTRUCTION VIEW

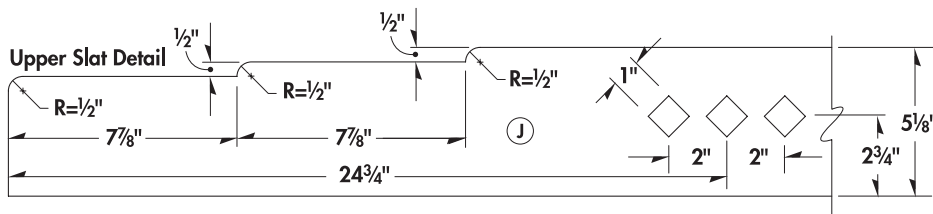

Joinery details can be found in the Patio Set article of issue 277 of Workbench Magazine (Pages 28-37)

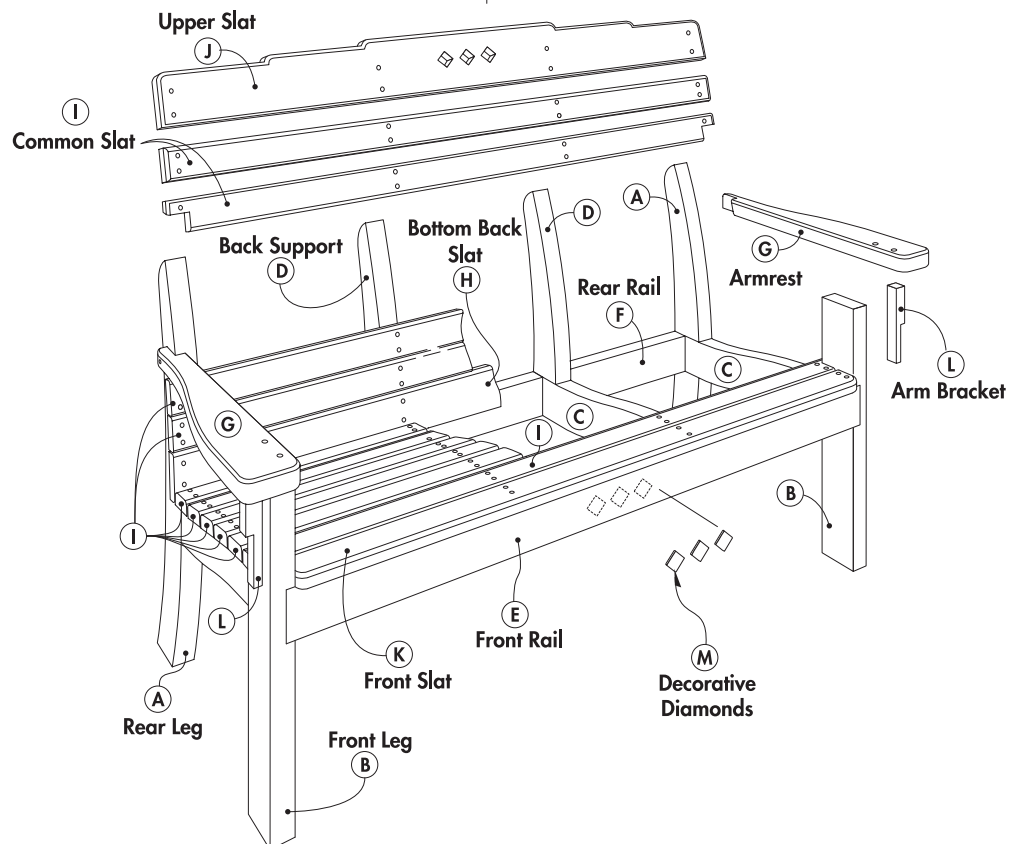

## CUTTING DIAGRAM

